

## CUSPED LIGHT-LIKE WILSON LOOPS IN GAUGE THEORIES

*I. O. Cherednikov*<sup>1,2,\*</sup>, *T. Mertens*<sup>1,\*\*</sup>, *F. F. Van der Veken*<sup>1,\*\*\*</sup>

<sup>1</sup>Departement Fysica, Universiteit Antwerpen, Antwerpen, Belgium

<sup>2</sup>Joint Institute for Nuclear Research, Dubna

We propose and discuss a new approach to the analysis of the correlation functions which contain light-like Wilson lines or loops, the latter being cusped in addition. The objects of interest are therefore the light-like Wilson null-polygons, the soft factors of the parton distribution and fragmentation functions, high-energy scattering amplitudes in the eikonal approximation, gravitational Wilson lines, etc. Our method is based on a generalization of the universal quantum dynamical principle by J. Schwinger and allows one to take care of extra singularities emerging due to light-like or semi-light-like cusps. We show that such Wilson loops obey a differential equation, which connects the area variations and renormalization group behavior of those objects, and discuss the possible relation between geometrical structure of the loop space and area evolution of the light-like cusped Wilson loops.

PACS: 11.10.Gh; 11.15.Pg; 11.15.Tk; 11.25.Tq; 11.38.Aw

### INTRODUCTION

Wilson lines (also known as gauge links or eikonal lines) can be naturally introduced in any gauge field theory. These objects are generically defined via traces of path-ordered exponentials of a gauge field evaluated along a given trajectory  $\mathcal{W}(\Gamma) = \mathcal{P} \exp \left[ -ig \int_{[\Gamma]} dz^\mu \mathcal{A}_\mu(z) \right]$ . The path  $\Gamma$  is a curve along which the gauge field  $\mathcal{A}$  gets transported from the initial point to the final one. Wilson lines defined on closed contours are called Wilson loops. They are path-dependent nonlocal functionals of the gauge field, invariant under gauge group transformations. Putting the matter of question more mathematical, one can construct a space with its elements being Wilson loops defined on an infinite set of contours. Reformulation of QCD in terms of the elements of a generic loop space would allow one to use gauge-invariant quantities as fundamental

---

\*E-mail: igor.cherednikov@ua.ac.be

\*\*E-mail: tom.mertens@ua.ac.be

\*\*\*E-mail: frederik.vanderveken@ua.ac.be

degrees of freedom instead of the quarks and gluons from the standard QCD Lagrangian [1,2]. Observables can then be obtained via correlation functions of Wilson loops:

$$\mathcal{W}_n(\Gamma_1, \dots, \Gamma_n) = \langle 0 | \mathcal{T} \frac{1}{N_c} \text{Tr} \Phi(\Gamma_1) \cdots \frac{1}{N_c} \text{Tr} \Phi(\Gamma_n) | 0 \rangle, \quad (1)$$

$$\Phi(\Gamma_i) = \mathcal{P} \exp \left[ ig \oint_{\Gamma_i} dz^\mu A_\mu(z) \right].$$

Complete information on the quantum dynamical properties of the loop space is accumulated in the Schwinger–Dyson equations:

$$\langle 0 | \nabla_\mu F^{\mu\nu} \mathcal{O}(A) | 0 \rangle = i \langle 0 | \frac{\delta}{\delta A_\nu} \mathcal{O}(A) | 0 \rangle, \quad (2)$$

where  $\mathcal{O}(A)$  stands for an arbitrary functional of the gauge fields. Let the functionals  $\mathcal{O}(A)$  be the Wilson exponentials  $\Phi(\Gamma)$  (1). Then Eqs. (2) turn into the Makeenko–Migdal (MM) equations [3]:

$$\partial_x^\nu \frac{\delta}{\delta \sigma_{\mu\nu}(x)} \mathcal{W}_1(\Gamma) = N_c g^2 \oint_{\Gamma} dz^\mu \delta^{(4)}(x-z) \mathcal{W}_2(\Gamma_{xz} \Gamma_{zx}), \quad (3)$$

where the basic operations are the area- $\delta/\delta\sigma_{\mu\nu}$  and the path- $\partial_\mu$  derivatives [3]:

$$\frac{\delta}{\delta \sigma_{\mu\nu}(x)} \Phi(\Gamma) \equiv \lim_{|\delta \sigma_{\mu\nu}(x)| \rightarrow 0} \frac{\Phi(\Gamma \delta \Gamma) - \Phi(\Gamma)}{|\delta \sigma_{\mu\nu}(x)|}, \quad (4)$$

and the contour  $\Gamma \delta \Gamma$  is obtained from the initial one by means of the infinitesimal area deformation  $\delta \Gamma$  at the point  $x$ , while the path variation without changing the area gives rise to the path derivative

$$\partial_\mu \Phi(\Gamma) = \lim_{|\delta x_\mu|} \frac{\Phi(\delta x_\mu^{-1} \Gamma \delta x_\mu) - \Phi(\Gamma)}{|\delta x_\mu|}. \quad (5)$$

The area derivative can be written as well in the so-called Polyakov form — see, e.g., [5] for a discussion of an alternative approach.

Note that the derivation of the MM equations from the Schwinger–Dyson equations is grounded on the Mandelstam formula

$$\frac{\delta}{\delta \sigma_{\mu\nu}(x)} \Phi(\Gamma) = ig \text{Tr} [F_{\mu\nu} \Phi(\Gamma_x)] \quad (6)$$

and/or on the Stokes theorem, so that the Wilson functionals which do not satisfy the corresponding restrictions (such as, e.g., cusped light-like loops) apparently

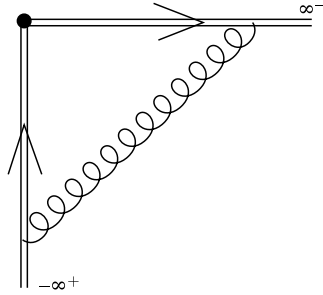

Fig. 1. The cusped integration contour on the light-cone with the one-gluon exchanges giving rise to the cusp anomalous dimension

cannot be straightforwardly treated within the same scheme. There are several other issues limiting the predictive power of the MM equations. Namely, there exists an interesting class of Wilson loops which possess very specific singularities originating, in particular, from the cusps and/or self-intersections of the contours and, in addition, from the light-like segments of the integration paths. The simplest example is given by a Wilson exponential evaluated along a cusped contour with two semi-infinite light-like sides, Fig. 1. Already the leading order contribution to this Wilson exponential possesses all the peculiar singularities: the pure ultraviolet, the infrared (due to the infinite lengths of the sides), and the light-like cusp divergences. This simple contour will arise in what follows as a building unit of many important Wilson loops and correlation functions. Physically it corresponds to the soft part of the factorized quark form factor, which has been studied in detail in [6, 7].

In the present work, we propose and discuss a new approach to these issues, having in mind, as an instructive example, a very special type of Wilson loops — planar rectangles with light-like sides. Considerable interest to cusped light-like Wilson polygons has arisen thanks to the recently conjectured duality between the  $n$ -gluon planar scattering amplitudes in the  $\mathcal{N} = 4$  super-Yang–Mills theory and the vacuum average of planar Wilson loops formed, correspondingly, by  $n$  light-like segments connecting space-time points  $x_i$ , so that their «lengths»  $x_i - x_{i+1} = p_i$  are chosen equal to the external momenta of the  $n$ -gluon amplitude (see, e.g., [8] and references therein). It has been demonstrated that the infrared singularities of the former correspond to the ultraviolet singularities of the latter, and the cusp anomalous dimension is the crucial constituent of the evolution equations [9].

Wilson exponentials possessing light-like segments (or that are fully light-like) have been studied also in a different context [6]. The main observation is that the renormalization properties of these Wilson loops are more intricate than those of cusped Wilson loops defined on off-light-cone integration contours. Namely, the light-cone cusped Wilson loops are not multiplicatively renormalizable because of the additional light-cone singularities (besides the standard ultraviolet and infrared ones). It is possible, however, to construct a combined renormalization-group equation taking into account ultraviolet as well as light-cone divergences. The cusp anomalous dimension, which is the principal ingredient of this equation, is remarkably universal: it controls, e.g., the infrared asymptotic behavior of such important quantities as the QCD and QED Sudakov

form factors, the gluon Regge trajectory, the integrated (collinear) parton distribution functions at large- $x$ , the anomalous dimension of the heavy quark effective theory, etc. [6, 7, 9, 10].

Another interesting field of application of cusped light-cone Wilson lines could be transverse-momentum-dependent parton densities (TMDs) [11, 12]. The latter are introduced to describe the intrinsic transverse momentum of partons inside the nucleon, which is needed in the study of semi-inclusive processes within (the generalization of) the QCD factorization formalism [11, 13].

### 1. EXAMPLE: SINGULARITY STRUCTURE OF TMDs

Let us discuss the emergent singularities arising in TMDs beyond the tree approximation. At one-loop level, the following three classes of divergences appear: (i) standard ultraviolet poles, which are removable by a normal renormalization procedure; (ii) pure rapidity divergences, which depend on an additional rapidity cutoff, but do not violate renormalizability of TMDs, they can be resumed by means of the Collins–Soper evolution equation; (iii) very specific overlapping divergences, they contain the ultraviolet and rapidity poles simultaneously and thus break down the standard renormalizability of TMDs. This situation resembles the problems with renormalizability of the light-like Wilson loops discussed above. However, the structure of Wilson lines is quite involved already in the tree approximation. The most straightforward definition of «a quark in a quark» TMD, which meets the requirement of the parton number interpretation, reads [14]

$$\begin{aligned} \mathcal{F}_{\text{unsub}}(x, \mathbf{k}_\perp) &= \frac{1}{2} \int \frac{d\xi^- d^2\xi_\perp}{2\pi(2\pi)^2} e^{-ik \cdot \xi} \times \\ &\times \langle p | \bar{\psi}_a(\xi^-, \boldsymbol{\xi}_\perp) \mathcal{W}_n^\dagger(\xi^-, \boldsymbol{\xi}_\perp; \infty^-, \boldsymbol{\xi}_\perp) \mathcal{W}_1^\dagger(\infty^-, \boldsymbol{\xi}_\perp; \infty^-, \infty_\perp) \times \\ &\times \gamma^+ \mathcal{W}_1(\infty^-, \infty_\perp; \infty^-, \mathbf{0}_\perp)_1 \mathcal{W}_n(\infty^-, \mathbf{0}_\perp; 0^-, \mathbf{0}_\perp)_n \psi_a(0^-, \mathbf{0}_\perp) | p \rangle, \quad (7) \end{aligned}$$

with  $\xi^+ = 0$ . Here, we define the semi-infinite Wilson lines evaluated along a four-vector  $w$  as

$$\mathcal{W}_w(\infty; \xi) \equiv \mathcal{P} \exp \left[ -ig \int_0^\infty d\tau w_\mu A_a^\mu t^a(\xi + w\tau) \right],$$

where the vector  $w$  can be light-like  $w_L = n^\pm$ ,  $(n^\pm)^2 = 0$ , or transverse  $w_T = \mathbf{1}$ . Formally, the integration of (7) over  $\mathbf{k}_\perp$  is expected to give the collinear

(also called integrated) PDF

$$\int d^2\mathbf{k}_\perp \mathcal{F}_{\text{unsub}}(x, \mathbf{k}_\perp) = \frac{1}{2} \int \frac{d\xi^-}{2\pi} e^{-ik^+\xi^-} \times \\ \times \langle p | \bar{\psi}_a(\xi^-, \mathbf{0}_\perp) \mathcal{W}_n(\xi^-, 0^-) \gamma^+ \psi_a(0^-, \mathbf{0}_\perp) | p \rangle = f_a(x). \quad (8)$$

However, this is only justified in tree approximation. It is worth noting that the normalization of the above TMD

$$\mathcal{F}_{\text{unsub}}^{(0)}(x, \mathbf{k}_\perp) = \frac{1}{2} \int \frac{d\xi^- d^2\xi_\perp}{2\pi(2\pi)^2} e^{-ik^+\xi^- + i\mathbf{k}_\perp \cdot \xi_\perp} \times \\ \times \langle p | \bar{\psi}(\xi^-, \xi_\perp) \gamma^+ \psi(0^-, \mathbf{0}_\perp) | p \rangle = \delta(1-x) \delta^{(2)}(\mathbf{k}_\perp) \quad (9)$$

can be most easily obtained by making use of the canonical quantization procedure in the light-cone gauge, where longitudinal Wilson lines become equal to unity and where equal-time commutation relations for creation and annihilation operators  $\{a^\dagger(k, \lambda), a(k, \lambda)\}$  immediately yield the parton number interpretation

$$\mathcal{F}_{\text{unsub}}^{(0)}(x, \mathbf{k}_\perp) \sim \langle p | a^\dagger(k^+, \mathbf{k}_\perp; \lambda) a(k^+, \mathbf{k}_\perp; \lambda) | p \rangle. \quad (10)$$

The usage of «tilted» gauge links in the operator definition of TMDs does not meet this requirement. We visualize the geometrical layout of various Wilson lines in the operator definition of TMDs in Figs. 2–4 and discuss relevant issues in their captions.

Beyond tree approximation, the virtual diagrams producing terms with overlapping singularities are shown in Fig. 5. The typical extra divergency stems from the one-loop vertex-type graph (Fig. 5, *a*) in covariant gauges or from the self-energy graph (Fig. 5, *b*) in the light-cone gauge (in the large- $N_c$  limit) and reads

$$\text{TMD}_{\text{UV}\otimes\text{LC}} = -\frac{\alpha_s N_c}{2\pi} \Gamma(\epsilon) \left[ 4\pi \frac{\mu^2}{-p^2} \right]^\epsilon \times \\ \times \delta(1-x) \delta^{(2)}(\mathbf{k}_\perp) \int_0^1 dx \frac{x^{1-\epsilon}}{(1-x)^{1+\epsilon}}. \quad (11)$$

The standard ultraviolet pole in the Gamma-function  $\Gamma(\epsilon)$  is accompanied by an additional singularity in the integral. The latter is due to the integration over infinite gluon rapidity and cannot be treated by dimensional regularization, calling for an extra (rapidity) cutoff. The reason for renormalizability violation in the leading order contribution to TMDs is that light-like Wilson lines (or the «standard» quark self-energy in light-cone gauge) produce more singular terms than the usual Green functions do.

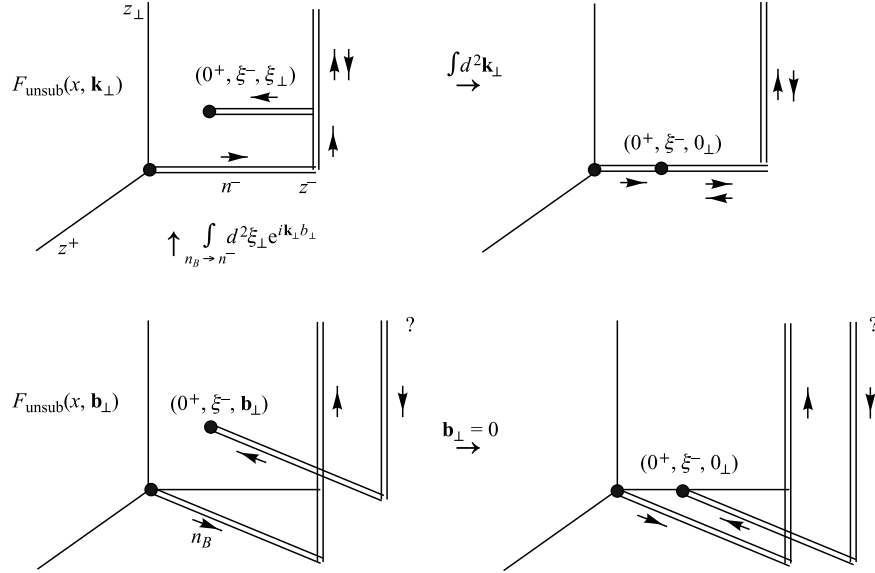

Fig. 2. Geometry of the contours in unsubtracted TMDs with light-like (upper panel) and off-light-cone (lower panel) longitudinal Wilson lines and their reduction to integrated PDFs in tree approximation. In the former case, the transverse Wilson lines vanish after  $\mathbf{k}_\perp$ -integration, while the longitudinal Wilson lines turn into one-dimensional connector  $\mathcal{W}_n(\xi^-, 0^-)$ . In the off-light-cone schemes, the mutual compensation of transverse Wilson lines at infinity is not visible. Moreover, the integrated configuration contains two nonvanishing off-light-cone Wilson lines, which apparently are not equivalent to the collinear connector  $\mathcal{W}_n(\xi^-, 0^-)$ . The interrogation marks next to the transverse Wilson lines symbolize the lacking of any consistent treatment in TMD formulations with off-light-cone (shifted) Wilson lines. In contrast, the transverse Wilson lines appear naturally in «light-cone» schemes

To solve the problems with extra singularities and renormalizability in TMDs, a variety of (possibly nonequivalent) methods has been proposed. Working in the covariant Feynman gauge, Ji, Ma, and Yuan proposed a scheme which utilizes tilted (off-light-cone) longitudinal Wilson lines directed along the vector  $n_B^2 \neq 0$  [15]. Transverse Wilson lines at the light-cone infinity cancel in covariant gauges, while the rapidity cutoff  $\zeta = (2p \cdot n_B)^2 / |n_B^2|$  marks the deviation of longitudinal Wilson lines from a pure light-like direction. A subtracted soft factor then contains nonlight-like Wilson lines as well. Obviously, such off-light-cone unsubtracted TMDs with the light-like vector  $n^-$  replaced by the vector  $n_B = (-e^{2y_B}, 1, \mathbf{0}_\perp)$  do not obey the equation (8), not even at tree level. However, it is possible to formulate a «secondary factorization» method which allows

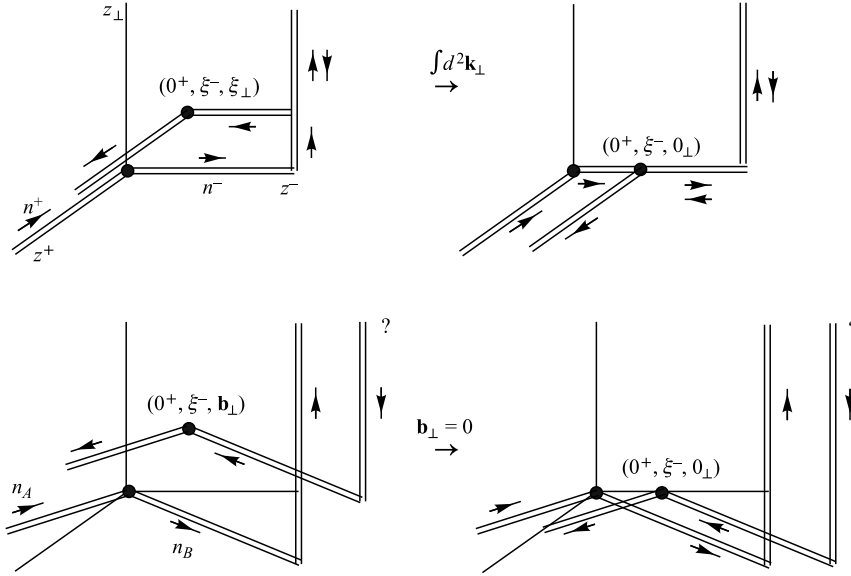

Fig. 3. Comparative layout of Wilson lines in unsubtracted soft factors and visualization of the reduction to the collinear case. The upper panel shows the soft factor in momentum space, as proposed in [12]. The lower panel presents the tilted off-light-cone integration paths in impact parameter space, as well as the result of the reduction to the collinear  $\mathbf{b}_{\perp} \rightarrow 0$  configuration

one to express off-light-cone TMDs (in impact parameter space  $\mathcal{F}(x, \mathbf{b}_{\perp})$ ) as a convolution of integrated PDFs and perturbative coefficient functions in the perturbative region (that is, at small  $\mathbf{b}_{\perp}$ ), see [15].

In publications [12], it was proposed to explore the renormalization-group properties of unsubtracted TMDs (7) and to make use of their anomalous dimension as a tool to discover the minimal layout of Wilson lines in the soft factor that provides a cancellation of overlapping dependent terms. It has been demonstrated (in the leading  $O(\alpha_s)$ -order) that the extra contribution to the anomalous dimension is exactly the cusp anomalous dimension [9], which is a crucial element of the investigation of nonrenormalizable cusped light-like Wilson loops. Making use of specially chosen soft factors, one can get rid of the extra divergences in the operator definition of the TMDs, however paying a price in the form of significant complication of the structure of the Wilson lines in the above definition. In the present work, we discuss another approach to the problems of light-cone cusped Wilson loops [16]. To this end, it appears instructive to study those properties shared by such apparently different quantities as TMDs, light-like Wilson poly-

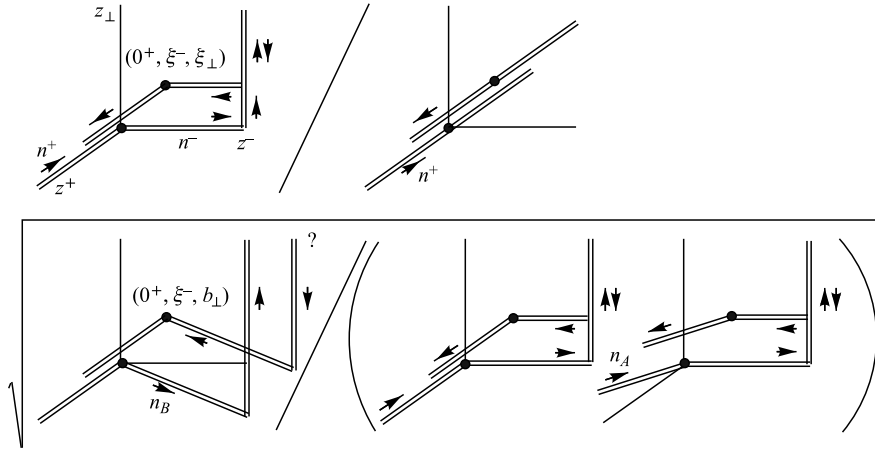

Fig. 4. Comparative layout of Wilson lines in subtracted soft factors. The upper panel corresponds to the soft factor of the TMD distribution function which enters the factorization with pure light-like Wilson lines. The lower panel has the same setup, but with the longitudinal Wilson lines shifted off the light cone

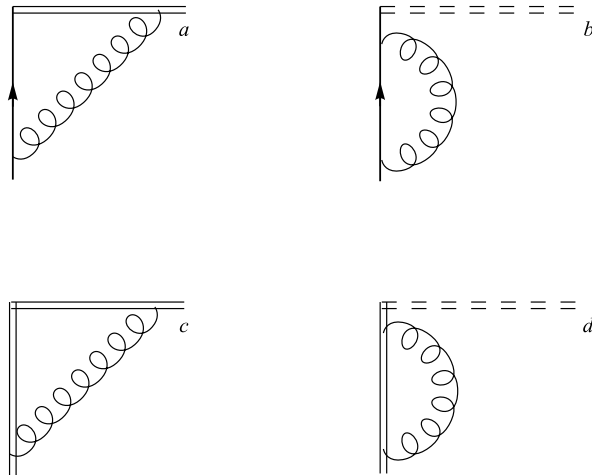

Fig. 5. The virtual one-loop Feynman graphs which produce extra singularities: *a*) vertex-type fermion-Wilson line interaction in covariant gauge; *b*) self-energy graph which yields the extra divergence in light-cone gauge; *c*, *d* are the counter-parts of *a*, *b* from the soft factor made of Wilson lines

gons, etc., which originate in their light-cone structure and arise in the form of the «too singular» nonrenormalizable terms.



## 2. SCHWINGER DYNAMICAL PRINCIPLE AND AREA EVOLUTION FOR SMOOTH WILSON LOOPS

We made use of the observation that in the large- $N_c$  limit, in the transverse null-plane, for the light-like planar dimensionally regularized (not renormalized) Wilson rectangles, the area derivatives introduced in the previous sections can be reduced to the normal ones. The area variational equations in the coordinate representation describe the evolution of light-like Wilson polygons and represent, therefore, the «equations of motion» in loop space, valid for a specific class of its elements. As a result, the obtained differential equations give us a closed set of dynamical equations for the loop functionals and can, in principle, be solved in several interesting cases.

Let us start with the quantum dynamical principle proposed by Schwinger [17]: the quantum action operator  $S$  defines variations of arbitrary states, so that

$$\delta \langle \alpha' | \alpha'' \rangle = \frac{i}{\hbar} \langle \alpha' | \delta S | \alpha'' \rangle. \quad (12)$$

The area variations (4) of field exponentials  $\Phi(\Gamma)$  yield

$$\frac{\delta}{\delta \sigma} \langle \alpha' | \Phi(\Gamma) | \alpha'' \rangle = \frac{i}{\hbar} \langle \alpha' | \frac{\delta \hat{S}}{\delta \sigma} \Phi(\Gamma) | \alpha'' \rangle, \quad (13)$$

where  $\hat{S}$  is yet to be defined. The loop space consists of scalar objects with different geometrical and topological features, hence the equations of motion in this space must be the laws which state how those objects change their shape. It means that «motion» in loop space is equivalent to the variation of the integration contours in Wilson loops [3]. Therefore, we have to find the correct operator  $\hat{S}$ , which governs the shape variations of the light-like cusped loops (Wilson null-polygons).

Within the standard approach, one utilizes (12) in the form (2) and obtains the set of the MM Eqs. (3). We will follow another strategy, trying to avoid using operations which implicitly assume the smoothness of the Wilson loops under consideration. For the sake of clarity, consider at first a generic Wilson loop  $W(\Gamma)$  without specifying whether it is smooth or not. Its perturbative expansion reads

$$\mathcal{W}(\Gamma) = \mathcal{W}^{(0)} + \mathcal{W}^{(1)} = 1 - \frac{g^2 C_F}{2} \oint_{\Gamma} \oint_{\Gamma} dz_{\mu} dz'_{\nu} D^{\mu\nu}(z - z') + O(g^4),$$

where  $D^{\mu\nu}$  is the free dimensionally regularized ( $\omega = 4 - 2\epsilon$ ) gluon propagator

$$D^{\mu\nu} = -g^{\mu\nu} \Delta(z - z'), \quad \Delta(z - z') = \frac{\Gamma(1 - \epsilon)}{4\pi^2} \frac{(\pi\mu^2)^{\epsilon}}{[-(z - z')^2 + i0]^{1-\epsilon}}. \quad (14)$$

For convenience's sake, we work in the Feynman covariant gauge and separate out the scalar part of the propagator  $\Delta(z)$ . The issues related to gauge and regularization independence of the calculations will be considered elsewhere. Therefore, the l.h.s. of Eq. (13), being applied to the Wilson loop (2), yields

$$\frac{\delta\mathcal{W}(\Gamma)}{\delta\sigma_{\mu\nu}} = \frac{g^2 C_F}{2} \frac{\delta}{\delta\sigma_{\mu\nu}} \oint_{\Gamma} \oint_{\Gamma} dz_{\lambda} dz'^{\lambda} \Delta(z - z') + O(g^4). \quad (15)$$

The area differentiation can be performed by making use of the Stokes theorem (let us assume for a moment that we are allowed to do so)

$$\oint_{\Gamma} dz_{\lambda} \mathcal{O}^{\lambda} = \frac{1}{2} \int_{\Sigma} d\sigma_{\lambda\rho} (\partial^{\lambda} \mathcal{O}^{\rho} - \partial^{\rho} \mathcal{O}^{\lambda}), \quad \mathcal{O}^{\lambda} = \oint_{\Gamma} dz'_{\lambda} \Delta(z), \quad (16)$$

where  $\Gamma$  is considered as the boundary of the surface  $\Sigma$ . One obtains then the leading perturbative term of the Makeenko–Migdal equation (3):

$$\partial_{\mu} \frac{\delta\mathcal{W}(\Gamma_{\circ})}{\delta\sigma_{\mu\nu}(x)} = \frac{g^2 N_c}{2} \oint_{\Gamma_{\circ}} dy_{\nu} \delta^{(\omega)}(x - y) + O(g^4). \quad (17)$$

We have to be careful with this result: in the course of the derivation, we assumed that the Stokes theorem is valid for all Wilson loops of interest. However, the last statement is not true in general; for that reason, we mark the «good» (smooth enough) contours with a special index  $\Gamma_{\circ}$ . It is worth noting that in 2D QCD the area differentiation is reduced to the ordinary derivative, since the gluon propagator (14) for  $\omega = 2$  behaves as the logarithm of  $z$ , what yields

$$\mathcal{W}(\Gamma_{\circ})^{2D} = \exp \left[ -\frac{g^2 N_c}{2} \Sigma \right], \quad \Sigma = \text{area inside } \Gamma_{\circ}, \quad (18)$$

so that  $2 \ln W'_{\Sigma} = -g^2 N_c$ . Calculating in a similar manner the next-to-leading terms, one can come to the full MM Eq. (3). Nevertheless, we shall stop at this point and make a couple of steps backward, since we are interested in those loops that apparently do not satisfy the Stokes theorem conditions. For this reason, we will try to learn something about the area variations of Wilson loops without using the Stokes theorem, but instead taking into account an explicit form for the gluon propagator (which develops a specific singularity on the light cone), Eq. (14).

### 3. SINGULARITIES OF WILSON RECTANGLES

We are now in a position to extend the Schwinger approach to a more complicated case and to try to derive the corresponding area evolution equations.

The calculation of cusped light-cone Wilson loops beyond tree approximation in different gauges and the justification of gauge independence calls for a careful treatment of a variety of divergences already in leading order. Special attention must be paid to the separation of the light-cone singularities and the standard ultraviolet poles [2,6,18]. In the large- $N_c$  limit one obtains in coordinate space [6]

$$W(\Gamma_\square) = 1 - \frac{1}{\epsilon^2} \frac{\alpha_s N_c}{2\pi} \left( [-2N^+ N^- \mu^2 + i0]^\epsilon + [2N^+ N^- \mu^2 + i0]^\epsilon \right) + \frac{\alpha_s N_c}{2\pi} \left( \frac{1}{2} \ln^2 \frac{N^+ N^- + i0}{-N^+ N^- + i0} + \text{finite terms} \right) + O(\alpha_s^2), \quad (19)$$

where the energy variables in momentum space,  $s = (p_1 + p_2)^2$  and  $t = (p_2 + p_3)^2$ , map onto the area variables in the coordinate transverse null-plane, so that  $s/2 = -t/2 \rightarrow N^+ N^-$ . We will show separately that the result (19) is not only gauge-invariant, but is independent of any regularization of light-cone and ultraviolet divergences and of the way they are separated. This issue is of particular importance to understand the operator structure of transverse-momentum-dependent parton densities and soft-collinear effective theory (see, e.g., [12,19] and references therein). The problem of regularization independence in the next-to-leading order deserves its own dedicated study.

The transverse null-plane is defined by the condition  $z_\perp = 0$ ; therefore, the area variations are well defined

$$\delta\sigma^{+-} = N^+ \delta N^-, \quad \delta\sigma^{-+} = -N^- \delta N^+. \quad (20)$$

These operations make sense only at the corner points  $x_i$ , and we distinguish between the «left» and «right» variations, as shown in Fig. 6.

$W(\Gamma_\square)$  is one of the best studied examples of (partially) light-like objects which are known to lack multiplicative renormalizability [6]. In order to decrease

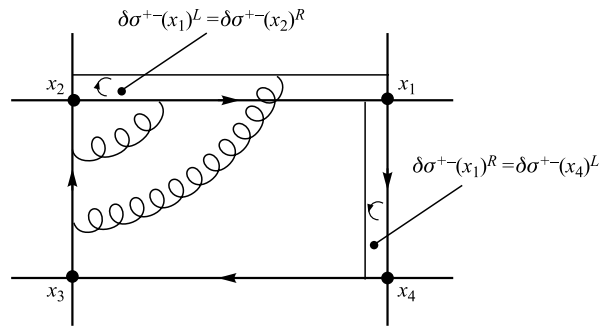

Fig. 6. Infinitesimal area transformations for a light-cone rectangle on the null-plane: we consider only those area variations that conserve the angles between the sides. These variations are defined at the corners  $x_i$

the power of singularity that violates the renormalizability, one can follow the scheme proposed in [7]. Having in mind Eq. (20), we define the area logarithmic derivative as

$$\frac{\delta}{\delta \ln \sigma} \equiv \sigma_{+-} \frac{\delta}{\delta \sigma_{+-}} + \sigma_{-+} \frac{\delta}{\delta \sigma_{-+}} \tag{21}$$

and apply this operator to the r.h.s. of Eq. (19):

$$\begin{aligned} \frac{\delta}{\delta \ln \sigma} \ln W(\Gamma_{\square}) &= \\ &= -\frac{\alpha_s N_c}{2\pi} \frac{1}{\epsilon} \left( [-2N^+ N^- \mu^2 + i0]^\epsilon + [2N^+ N^- \mu^2 + i0]^\epsilon \right). \end{aligned} \tag{22}$$

Then the finite cusp anomalous dimension results from

$$\mu \frac{d}{d\mu} \frac{\delta \ln W(\Gamma_{\square})}{\delta \ln \sigma} = -4\Gamma_{\text{cusp}}, \quad \Gamma_{\text{cusp}} = \frac{\alpha_s N_c}{2\pi} + O(\alpha_s^2). \tag{23}$$

We get the finite result (23) by making use of the logarithmic area derivative (21), given that the infinitesimal area variations are defined as in (4). The equation (23) describes the dynamical properties of the light-like Wilson loops [16]. We relate, therefore, the geometry of the loop space (expressed in terms of the area differentials) to the dynamics of the fundamental degrees of freedom — the gauge-invariant, regularization-independent light-like Wilson loops.

#### 4. COMBINED EVOLUTION FROM THE SCHWINGER PRINCIPLE

The very possibility to obtain a finite result by means of Eqs. (22), (23) is a direct consequence of the geometrical properties of loop space, whose constituents are nonrenormalizable cusped light-like Wilson loops. To show this explicitly, we restrict ourselves to area variations (20), and apply the area derivative to a Wilson rectangle

$$\begin{aligned} \frac{\delta W(\Gamma_{\square})}{\delta \sigma_{\mu\nu}} &= \frac{g^2 C_F}{2} \frac{\Gamma(1-\epsilon)(\pi\mu^2)^\epsilon}{4\pi^2} \frac{\delta}{\delta \sigma_{\mu\nu}} \sum_{i,j} (v_j^\lambda v_j^\lambda) \times \\ &\times \int_0^1 \int_0^1 \frac{d\tau d\tau'}{[-(x_i - x_j - \tau_i v_i + \tau_j v_j)^2 + i0]^{1-\epsilon}}, \end{aligned} \tag{24}$$

where the sides of the rectangle are parameterized as  $z_i^\mu = x_i^\mu - v_i^\mu \tau$  with vectors  $v_i$  having dimension [mass<sup>-1</sup>] [6]. A remarkable feature of light-like loops is

that the area dependence factorizes out from the integrals and can be evaluated explicitly (taking into account that  $2(v_1 v_2) = 2N^+ N^-$ , see Eq. (20)):

$$W^{(1)}(\Gamma_{\square}) = -\frac{\alpha_s N_c}{2\pi} \Gamma(1-\epsilon) (\pi\mu^2)^\epsilon (-2N^+ N^-)^\epsilon \frac{1}{2} \int_0^1 \int_0^1 \frac{d\tau d\tau'}{[(1-\tau)\tau']^{1-\epsilon}}. \quad (25)$$

On the other hand, light-like Wilson lines with  $v_i^2 = 0$  produce an extra singularity, which shows up in the form of the second-order pole  $\sim \epsilon^{-2}$ , while the cusps violate conformal invariance of the Wilson loop because the «skewed» scalar products  $(v_i v_j) \neq 0$  replace the conformal ones  $v_i^2$ . Then, performing the area  $\delta/\delta \ln \sigma = \delta/\delta \ln (2N^+ N^-)$  and the mass logarithmic differentiation of Eq. (25) and collecting all relevant terms, we come to the result

$$\mu \frac{d}{d\mu} \left[ \frac{\delta}{\delta \ln \sigma} \ln W(\Gamma) \right] = -\sum \Gamma_{\text{cusp}}, \quad (26)$$

which was anticipated in Eq. (23) and which is derived now as a direct consequence of the Schwinger approach. It is not surprising that this result resembles, in some sense, the situation in 2D QCD considered above. The area derivative turns into the ordinary derivative for the same reason: the null-plane is effectively a two-dimensional space, where the set of MM equations becomes closed and — at least in principle — solvable [3,4].

Note that the r.h.s. of Eq. (26) is given by the cusp anomalous dimension, which is universal quantity (independent of the form of the contour) and which is known perturbatively up to the  $O(\alpha_s^3)$  order. It is, therefore, worth analyzing if the above result is only a leading order approximation, or if it is expected to be valid in the higher orders as well. Let us take into account the property of linearity of the (angle-dependent) cusp anomalous dimension in the large-angle asymptotic regime with respect to the logarithm of the cusp angle  $\chi \rightarrow \frac{1}{2} \ln \frac{(2v_i v_j)^2}{v_i^2 v_j^2}$  [9]:

$$\lim_{\chi \rightarrow \infty} \Gamma_{\text{cusp}}(\chi, \alpha_s) = \sum \alpha_s^n C_n(W) a_n(W) \ln \frac{(2v_i v_j)}{|v_i| |v_j^2|}, \quad (27)$$

where the «maximally non-Abelian» numerical coefficients are

$$C_k \sim C_F N_c^{k-1} \rightarrow \frac{N_c^k}{2}, \quad (28)$$

and  $a_n$  are the cusp-independent factors. This regime corresponds exactly to the light-cone case with the angle-dependent logarithms being transformed into additional poles in  $\epsilon$ :  $\chi \rightarrow (v_i v_j)^\epsilon / \epsilon$ , see [6,9]. More specifically, the area

variable  $\sim (v_i v_j)$  enters the regularized area-dependent cusp anomalous dimension in the light-cone limit as

$$\Gamma_{\text{cusp}}(\text{area}, \epsilon, \alpha_s) = \sum \alpha_s^n C_n(W) a_n(W) \frac{\text{area}^\epsilon}{\epsilon}, \tag{29}$$

and, after logarithmic area differentiation, one gets the finite perturbative expansion of the cusp anomalous dimension

$$\lim_{\epsilon \rightarrow 0} \frac{d\Gamma_{\text{cusp}}(\text{area}, \epsilon, \alpha_s)}{d \ln \text{area}} = \sum \alpha_s^n C_n(W) a_n(W), \tag{30}$$

which supports the validity of the previous result (26) in the higher orders by virtue that

$$\Gamma_{\text{cusp}} = - \frac{d \ln W}{d \ln \mu}.$$

This means that the result (26) should be understood as an all-order one, akin the MM Eq.(3): they both are exact and nonperturbative, while the r.h.s's of each one can be evaluated order by order in perturbation theory. It is worth noting that Eq.(23) is consistent with the non-Abelian exponentiation of the dimensionally regularized Wilson loops with cusps

$$W(\Gamma_{\square}; \epsilon) = \exp \left[ \sum_{k=1} \alpha_s^k C_k(W) F_k(W) \right], \tag{31}$$

where the summation goes over all two-particle irreducible diagrams, whose contribution is given by the «web» functions  $F_k$  [9,20]. Therefore, Eq.(23) can be applied, in principle, for computing the higher-order perturbative corrections to the cusp anomalous dimension, given that we have a closed recursion of the perturbative equations.

Besides, for rectangular light-like Wilson loops on the null-plane, Eq.(26) is valid for transverse-momentum densities with longitudinal gauge links on the light cone  $\Phi(x, \mathbf{k}_\perp)$ , such that

$$\mu \frac{d}{d\mu} \left[ \frac{d}{d \ln \theta} \ln \Phi(x, \mathbf{k}_\perp) \right] = 2\Gamma_{\text{cusp}}, \tag{32}$$

where the corresponding area is encoded in the rapidity cutoff parameter  $\theta \sim (N^+ N^-)^{-1}$  [12]. Another interesting example is given by the  $\Pi$ -shape loop with one (finite) segment lying on the light cone [21]. In the one-loop order one has in the large- $N_c$  limit

$$W(\Gamma_{\Pi}) = 1 + \frac{\alpha_s N_c}{2\pi} + \left[ -L^2(NN^-) + L(NN^-) - \frac{5\pi^2}{24} \right], \tag{33}$$

$$L(NN^-) = \frac{1}{2} \left( \ln(\mu NN^- + i0) + \ln(\mu NN^- + i0) \right)^2,$$

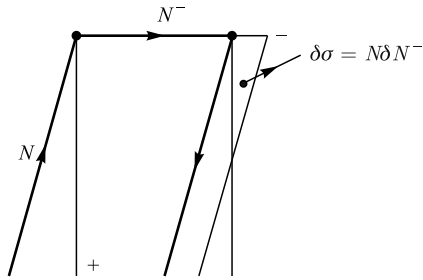

Fig. 7. II-shape integration contour and the infinitesimal area variations

where the area is defined by the product of the light-like  $N^-$  and nonlight-like  $N$  vectors in the coordinate space, see Fig. 7. The II-shaped Wilson loop (33) also satisfies Eq. (26):

$$\mu \frac{d}{d\mu} \left[ \frac{d}{d \ln \sigma} \ln W(\Gamma_{\Pi}) \right] = -2\Gamma_{\text{cusp}}, \quad (34)$$

the latter being responsible for the renormalization-group behavior of the collinear parton densities in the large- $x$  regime and for the anomalous dimensions of conformal operators with large Lorentz spin [21]. The II-shape contour can be split and moved apart to separate two planes by the transverse distance  $\xi_{\perp}$ . The Wilson loop obtained in such a way is expected to be «dual» to the TMD, see Fig. 8. The detailed analysis of this configuration will be presented elsewhere.

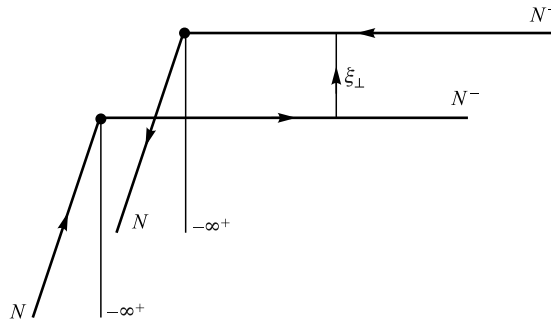

Fig. 8. Conjectured «dual» Wilson loop having the combined evolution similar to the one of a TMD. Transverse Wilson lines are not shown for simplicity

### 5. CONCLUSIONS AND OUTLOOK

The universal quantum dynamical approach formulated by Schwinger provides a relevant description of the geometrical and dynamical properties of loop space. The Wilson loops of arbitrary shape are considered then as fundamental degrees of freedom, and the Makeenko–Migdal equations (3) can be derived from the Schwinger–Dyson equations for renormalizable loops. In general, the system of MM equations is not closed and cannot be straightforwardly applied to a practical calculation in QCD.

The problem we addressed in this paper is how to construct a relevant system of equations of motion valid for cusped light-like Wilson loops, taking into

Fig. 9. Generic infinitesimal area variations responsible for the conjectured quantum-dynamical loop equations for light-like Wilson  $n$  polygons. Evaluation of minimal surface differentials for more complicated cusped Wilson loops is required to derive corresponding area evolution equations based on the quantum dynamical principle [22]

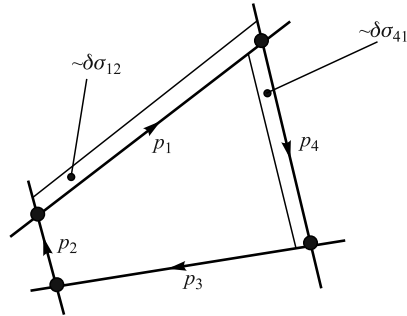

account that the latter possess a very specific singularity structure compared to their off-light-cone relatives. A general solution of this problem is not achieved yet, but we have demonstrated that some simplifications make it possible to propose a new potentially fruitful method. In particular, in the large- $N_c$  limit and in the case of planar rectangular light-like Wilson loops defined on the null-plane  $\mathbf{z}_\perp = 0$ , the area functional derivative is reduced to the normal derivative for dimensionally regularized Wilson loops. The area evolution equations (which can be treated as the nonrenormalizable counterparts of the MM equations) in coordinate space appear to be equivalent to the energy evolution equations for cusped Wilson loops in momentum space. The nonperturbative nature of the dynamical loop equations enables us, in principle, to construct a chain of equations for, e.g., the cusp anomalous dimension, so that one can calculate it recursively for any given order in  $\alpha_s$ . Within the framework we proposed, the dynamics of elements of loop space are introduced by means of obstructions of initially smooth Wilson loops, which play, therefore, the role of *sources* in the Schwinger fields-sources picture. We have argued that the Schwinger quantum dynamical principle can be used as an effective tool to study at least one special class of elements of loop space, cusped Wilson exponentials on the light cone. We implemented the program only in one of the simplest cases, a rectangular contour on the transverse null-plane. In Fig. 9, a more involving configuration is visualized, an arbitrary quadrilateral integration contour, of which the area evolution is far from being trivial and deserves a separate study.

**Acknowledgements.** We appreciate stimulating discussions and useful critical remarks by I. V. Anikin, Y. M. Makeenko, and N. G. Stefanis.

#### REFERENCES

1. *Mandelstam S.* // Phys. Rev. 1968. V. 175. P. 1580;  
*Wilson K. G.* // Phys. Rev. D. 1974. V. 10. P. 2445;  
*Nambu Y.* // Phys. Lett. B. 1979. V. 80. P. 372;  
*Polyakov A. M.* // Ibid. V. 82. P. 247.



2. Polyakov A. M. // Nucl. Phys. B. 1979. V. 164. P. 171;  
Dotsenko V. S., Vergeles S. N. // Nucl. Phys. B. 1980. V. 169. P. 527;  
Arefeva I. Ya. // Phys. Lett. B. 1980. V. 93. P. 347;  
Craigie N. S., Dorn H. // Nucl. Phys. B. 1981. V. 185. P. 204;  
Aoyama S. // Nucl. Phys. B. 1982. V. 194. P. 513;  
Stefanis N. G. // Nuovo Cim. A. 1984. V. 83. P. 205;  
Balitsky I. I., Braun V. M. // Nucl. Phys. B. 1989. V. 311. P. 541.
3. Makeenko Y. M., Migdal A. A. // Phys. Lett. B. 1979. V. 88. P. 135; Erratum // Phys. Lett. B. 1980. V. 89. P. 437; Nucl. Phys. B. 1981. V. 188. P. 269;  
Migdal A. A. // Ann. Phys. 1977. V. 109. P. 365; Ann. Phys. 1980. V. 126. P. 279; Phys. Rep. 1983. V. 102. P. 199.
4. Brandt R. A., Neri F., Sato M.-A. // Phys. Rev. D. 1981. V. 24. P. 879;  
Brandt R. A. et al. // Phys. Rev. D. 1982. V. 26. P. 3611.
5. Kernemann A., Stefanis N. G. // Phys. Rev. D. 1989. V. 40. P. 2103;  
Stefanis N. G. hep-th/9607063;  
Gellas G. C. et al. // Phys. Lett. B. 1997. V. 412. P. 95;  
Karanikas A. I., Ktorides C. N. // JHEP. 1999. V. 11. P. 033;  
Karanikas A. I., Ktorides C. N., Stefanis N. G. // Eur. Phys. J. C. 2003. V. 26. P. 445.
6. Korchemskaya I. A., Korchemsky G. P. // Phys. Lett. B. 1992. V. 287. P. 169;  
Bassetto A. et al. // Nucl. Phys. B. 1993. V. 408. P. 62;  
Korchemsky G. P. // Mod. Phys. Lett. A. 1989. V. 4. P. 1257;  
Korchemsky G. P., Marchesini G. // Phys. Lett. B. 1993. V. 313. P. 433;  
Korchemsky G. P., Drummond J. M., Sokatchev E. // Nucl. Phys. B. 2008. V. 795. P. 385.
7. Ivanov S. V., Korchemsky G. P., Radyushkin A. V. // Yad. Fiz. 1986. V. 44. P. 230;  
Korchemsky G. P., Radyushkin A. V. // Phys. Lett. B. 1986. V. 171. P. 459;  
Korchemsky G. P. // Phys. Lett. B. 1989. V. 217. P. 330; V. 220. P. 629;
8. Alday L. F., Maldacena J. M. // JHEP. 2007. V. 06. P. 064;  
Alday L. F. et al. // JHEP. 2011. V. 09. P. 123;  
Beisert N. et al. // Lett. Math. Phys. 2012. V. 99. P. 3;  
Giordano M., Peschanski R., Seki S. // Acta Phys. Polon. B. 2012. V. 43. P. 1289.
9. Korchemsky G. P., Radyushkin A. V. // Nucl. Phys. B. 1987. V. 283. P. 342.
10. Karanikas A. I., Ktorides C. N., Stefanis N. G. // Phys. Rev. D. 1995. V. 52. P. 5898;  
Gellas G. C. et al. // Phys. Lett. B. 1997. V. 412. P. 95;  
Karanikas A. I. et al. // Phys. Lett. B. 1999. V. 455. P. 291.
11. Collins J. C., Soper D. E. // Nucl. Phys. B. 1981. V. 193. P. 381; 1982. V. 194. P. 445;  
Collins J. C., Hautmann F. // Phys. Lett. B. 2000. V. 472. P. 129;  
Hautmann F. // Phys. Lett. B. 2007. V. 655. P. 26;  
Collins J. C. // Acta Phys. Polon. B. 2003. V. 34. P. 3103.
12. Cherednikov I. O., Stefanis N. G. // Phys. Rev. D. 2008. V. 77. P. 094001; Nucl. Phys. B. 2008. V. 802. P. 146; Phys. Rev. D. 2009. V. 80. P. 054008;  
Stefanis N. G., Cherednikov I. O. // Mod. Phys. Lett. A. 2009. V. 24. P. 2913;  
Cherednikov I. O., Karanikas A. I., Stefanis N. G. // Nucl. Phys. B. 2010. V. 840. P. 379.

13. *Collins J. C., Soper D. E., Sterman G.* // Adv. Ser. Direct.-High Energy Phys. 1988. V. 5. P. 1; arXiv:hep-ph/0409313;  
*Belitsky A. V., Radyushkin A. V.* // Phys. Rep. 2005. V. 418. P. 1;
14. *Belitsky A. V., Ji X., Yuan F.* // Nucl. Phys. B. 2003. V. 656. P. 165;  
*Boer D., Mulders P. J., Pijlman F.* // Ibid. V. 667. P. 201.
15. *Ji X., Ma J., Yuan F.* // Phys. Rev. D. 2005. V. 71. P. 034005.
16. *Cherednikov I. O., Mertens T., Van der Veken F. F.* // Phys. Rev. D. 2012 (in press); arXiv:1208.1631 [hep-th]; arXiv:1208.5410 [hep-th].
17. *Schwinger J. S.* // Phys. Rev. 1951. V. 82. P. 914.
18. *Collins J. C.* // Intern. J. Mod. Phys. Conf. Ser. 2011. V. 4. P. 85;  
*Cherednikov I. O., Stefanis N. G.* // Intern. J. Mod. Phys. Conf. Ser. 2011. V. 4. P. 135;  
*Chiu J.-y. et al.* // JHEP. 2012. V. 05. P. 084; Phys. Rev. Lett. 2012. V. 108. P. 151601;  
*Avsar E.* arXiv:1203.1916 [hep-ph];  
*Cherednikov I. O.* // PoS. 2012. V. QNP. P. 061; arXiv:1206.4212 [hep-ph].
19. *Idilbi A., Scimemi I.* // Phys. Lett. B. 2011. V. 695. P. 463;  
*García-Echevarría M., Idilbi A., Scimemi I.* // Phys. Rev. D. 2011. V. 84. P. 011502(R); arXiv:1111.4996 [hep-ph];  
*Li Y., Mantry S., Petriello F.* // Phys. Rev. D. 2011. V. 84. P. 094014;  
*Mantry S., Petriello F.* arXiv:1108.3609 [hep-ph].
20. *Gatheral J. G. M.* // Phys. Lett. B. 1993. V. 133. P. 90;  
*Frenkel J., Taylor J. C.* // Nucl. Phys. B. 1984. V. 246. P. 231;  
*Mitov A., Sterman G., Sung I.* // Phys. Rev. D. 2010. V. 82. P. 096010;  
*Erdogan O., Sterman G.* arXiv:1112.4564 [hep-th].
21. *Korchensky G. P., Marchesini G.* // Nucl. Phys. B. 1993. V. 406. P. 225;  
*Makeenko Y.* // JHEP. 2003. V. 01. P. 007.
22. *Drukker N., Gross D. J., Ooguri H.* // Phys. Rev. D. 1999. V. 60. P. 125006;  
*Makeenko Y., Olesen P., Semenoff G. W.* // Nucl. Phys. B. 2006. V. 748. P. 170.